

Installation Information for the MC11

IMPORTANT NOTICE

THIS INFORMATION SHEET CONTAINS INSTRUCTIONS FOR INSTALLING AN MC11. FAILURE TO COMPLY WITH THESE MAY RESULT IN EQUIPMENT DAMAGE AND MAY PREJUDICE WARRANTY PROTECTION.

IT IS ESSENTIAL TO INSTALL THE GROUND CONNECTIONS AS DESCRIBED. FAILURE TO CONNECT THE GROUND SYSTEM CAN RESULT IN AN UNSAFE SITUATION, DAMAGE TO SENSORS, ACTUATORS AND ELECTRONIC SYSTEMS AND IMPROPER SYSTEM OPERATION.

SPHERE SYSTEMS PTY LTD CANNOT ACCEPT RESPONSIBILITY FOR INCORRECTLY INSTALLED EQUIPMENT AND MAY, AT ITS OPTION, CHARGE A SERVICE FEE FOR PROBLEMS RELATED TO INCORRECT INSTALLATIONS.

1. Mechanical & Environmental

The MC11 system is to be installed in 3.25" wide snap track fixed inside metal enclosures. Individual modules are snapped into place and can be removed by using the screwdriver cutouts along both edges of each board. Care must be taken not to apply excessive twist to the board during installation or removal. The printed circuit board must be mounted in a vertical plane. All wiring must be kept away from the components on the board and it is recommended that wiring be installed in conduits located parallel to each row of snap track.

The allowable operating temperature range is from -10C to +45C, non-condensing.

2. Power Supply

The MC11 is designed to be powered by 15 Volt DC. A Sphere power supply is available. All power must be removed from the system during field wiring connections. This includes power to the MC11, sensors, actuators and other power which could cause damage due to inadvertent shorts from loose wiring.

3. Communication cables

The MC11 communication interface can be selected to be RS232 or RS485 by means of two jumpers as shown in the above diagram. When a single jumper is connected as shown by the solid bar, the MC11 is configured with a RS232 interface. When two jumpers are inserted as shown by the empty boxes, the MC11 is configured to run with a RS485 interface. To use the MC11 on a network controlled by a DP11, RS485 must be selected.

3.1 RS232

The RS232 mode allows the MC11 to be connected to a PC. The communication parameters are 9600 baud, 8 data bits, one stop bit and no parity. The RS232 connection is a via a 10 pin ribbon cable. It is pin compatible with a PC 9 pin COM1 connector. The matching connector is a female type allowing the use of standard extension cables. When extending this cable the RS232 specification should be followed and the cable length should be kept to below 15 metres. Longer lengths *may* work but are not guaranteed to work. PC 9 pin connections are as follows:

Pin number	Connection
1	DCD*
2	RXD
3	TXD
4	DTR*
5	GND
6 - 9	No connection

The DCD and DTR connections are only used when the MC11 is directly connected to a modem. To connect the MC11 to COM2 a 25 to 9 way cable is required. For either COM port you will need to use a null modem.

MC-DP 9 pin	9 Pin conversion	
	MODEM	Null MODEM
1 DCD	1 DCD	1 DCD
2 RXD	2 TXD	3 RXD
3 TXD	3 RXD	2 TXD
4 DTR	4 DTR	4 DTR
5 GND	5 GND	5 GND

MC11 to DP 9 pin	25 Pin conversion	
	MODEM	Null MODEM
1 DCD	8 DCD	8 DCD
2 RXD	2 TXD	3 RXD
3 TXD	3 RXD	2 TXD
4 DTR	20 DTR	20 DTR
5 GND	7 GND	7 GND

3.2 RS485

RS485 is used when the MC11 is networked. The network cable must be a constant impedance, shielded, twisted pair meeting the EIA485 standard. The cable must be installed as a single run with no stubs or tees. The cable must be terminated by resistors at each end. For connections between the DP11 network processor and the MC11 a single pair is required connected to the COM+ and COM- terminals. Beyond a repeater two twisted pairs are required with the second pair connected to the TRX+ and TRX- terminals. The polarity of all pairs must be maintained, ie COM+ to COM+ etc.

The cable must be installed according to the Austel Customer Premises Wiring Standard. RS485 cabling is vulnerable to electrical noise. This may be caused by high currents or spikes on power wiring. This can damage network components. Keep data cabling well clear of all power

wiring. It is absolutely essential that a MC11 network is only grounded at one point. Failure to do this will result in errors in data transmission and may result in equipment damage due to differences in building ground potentials.

The correct installation is for all network nodes and their power supplies to be isolated from the building ground. The required ground reference between network nodes is provided through the communication cable shield. At one and only one point in the network is the shield tied to ground for safety.

4. Field Wiring

4.1 Outputs

The outputs on the MC11 can source 20mA and can sink 50mA. The output voltage range is 0 to nominally 10 VDC.

The MC311 processor has 8 output channels. Four channels (1 through 4) are digital outputs and four channels (5 through 8) are universal outputs and can be used as either analogue output or digital outputs. There is no need to program these universal outputs. If you write to them as analogue channels they will become analogue channels using pulse width modulation. If you write to them as digital channels then they will behave as digital channels. They will stay in the mode they were last written to.

4.1.1 Connections for analogue outputs

An analogue output supplies a 0 to 10V dc actuator drive signal by means of pulse width modulation. The output is switched rapidly between 0 and 12 VDC so that the average output voltage is the required value. This form of drive is compatible with most 0 to 10 volt valve and damper motors. This voltage is referenced to the MC11 ground (labelled GD) and it is essential to provide a two wire connection (both output and ground return) from the MC11 to the actuator. Motor power, often 24V AC, can either be fed from a daisy-chained single wire from the transformer, with the 24V AC return from the transformer connected to a ground terminal on the MC11 or a 3 wire connection can be made to the motor with the 24V AC being connected to a common tie point near the MC11. The latter is recommended for best noise immunity.

If the ground reference to the motor is not maintained (eg by using a floating transformer) then motor power would be applied to the analogue output and the MC11 may be damaged. This would not be covered by warranty.

4.1.2 Connections for digital outputs

The digital outputs are driven by power MOSFET drivers which switch to ground. These are designed to switch low voltage relay coils. Although the MOSFET drivers incorporate reverse-biased diodes for protection against inductive kick-back voltages which occur when relays are released, high inductance coils may need additional diodes fitted across the relay coils.

4.2 Inputs

The MC11 has eight input channels which can be used as either analogue or digital channels (or even as both simultaneously).

4.2.1 Connections for digital inputs

To use an input as a digital channel, the sensor must either apply a voltage to the input or provide a voltage-free contact closure. To be recognised as OFF the voltage must be > 6.6 VDC and to be recognised as ON the voltage must be < 3.3 VDC. This may appear counter-intuitive but is consistent with polarity interpretation for voltage-free contacts. The polarity may be reversed through programming.

To be used with voltage-free switch closures a jumper must be inserted to provide an internal current source to the input. An external switch from this input to ground will be recognised as ON when the switch is closed and OFF when it is open. Mechanical switches do not have polarity associated with them. Electronic switches do require correct polarity and colour-coded wire may assist in maintaining polarity. For short runs (under 20 metres) it is permissible to use wire such as telephone cable but for long runs it is desirable to use a heavier gauge of cable such as building wire. It is not recommended to use a thin single strand cable where there is any chance of movement in the cable as repeated flexure of such cable can result in a fracture.

4.2.2 Connections for analogue inputs.

The allowable voltage range for inputs is 0 to 10 volts referenced to the MC11 ground. The ground is externally accessed at connections labelled GD. The wiring to an analogue input sensor should be shielded to prevent noise pick-up unless the sensor source impedance is very low or a current source sensor is used with a low load impedance. It is not necessary to use a twisted pair although this is recommended. For an active sensor (ie one requiring a power supply) a shielded twisted pair cable may be used with the shield of the cable providing the ground reference for the sensor, one wire of the pair providing the power and the other wire for the sensor output. This convention should not be used where noise on the power supply may cause interference with the signal.

Where active sensors are used there must be a physical connection between the input terminal on the MC11 and the output terminal on the sensor as well as a physical connection between the ground terminal on the MC11 and the ground terminal on the sensor. The 24V AC power source for the sensor can be daisy-chained from sensor to sensor with the 24V AC return for the sensors being terminated at a MC11 ground terminal. Alternatively the 24V AC power for each sensor can be fed from a common tie-point near the MC11.

To disconnect a sensor you must not remove the ground wire, only the signal and 24V AC lines can be disconnected. Always turn off the power before disconnecting or reconnecting motors or sensors.

Questions

If you are unsure about the compatibility or the connection details of any field equipment with the MC11, contact Sphere Engineering prior to risking damage to any equipment.

Ph: +613 9457 6994

Fax: +613 9457 6995

Email: support@spheresystems.com.au

<http://www.spheresystems.com.au>

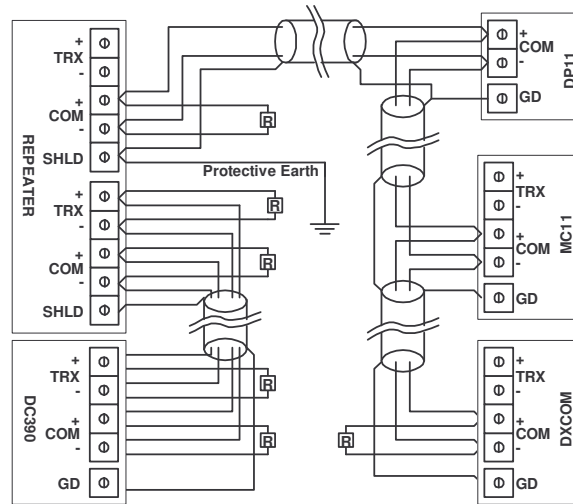

MC11 PCB Notes:

- 1 Network activity LED
- 2 RS485/RS232 Selection Jumper
- 3 Firmware name and revision date
- 4 MC11 ID number
- 5 External Backup battery connection
- 6 Power-on initialisation selectors (read ONLY on power-up)
 1. Jumper to enable RS485 (see also note 2)
 2. Jumper for Cold Reset (**DO NOT LEAVE JUMPERED**)
 3. DO NOT USE
 4. Jumper to set network Baud rate to 41K, remove for 9600 Baud
- 7 Jumper to set inputs to Digital
- 8 MC11 PCB revision number
- 9 Digital Input LED indication
- 10 3 Volt Lithium backup battery for non-volatile memory

